

# PACK NERO • TUBES

Réf 87

**BURGER.fr**

## CONFORME AUX NORMES NF P 01-012 & NF P 01-013 POUR UN USAGE PRIVÉ ET PUBLIC

- CONFORME A LAS NORMAS NF P 01-012 & NF P 01-013 PARA UN USO PRIVADO
- CONFORME ÀS NORMAS NF P 01-012 & NF P 01-013 PARA USO PRIVADO
- CONFORME ALLE NORME NF P 01-012 & NF P 01-013 PER L'USO PRIVATO
- VOLDOET AAN DE NORMEN NF P 01-012 & NF P 01-013 VOOR PRIVEGEBARUIK
- MEETS STANDARDS NF P 01-012 & NF P 01-013 FOR DOMESTIC USE

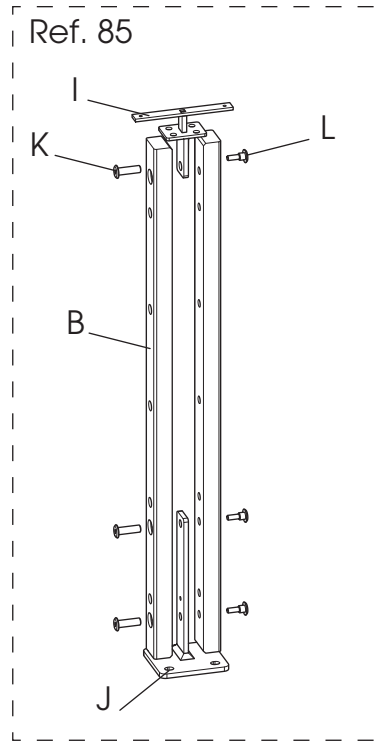
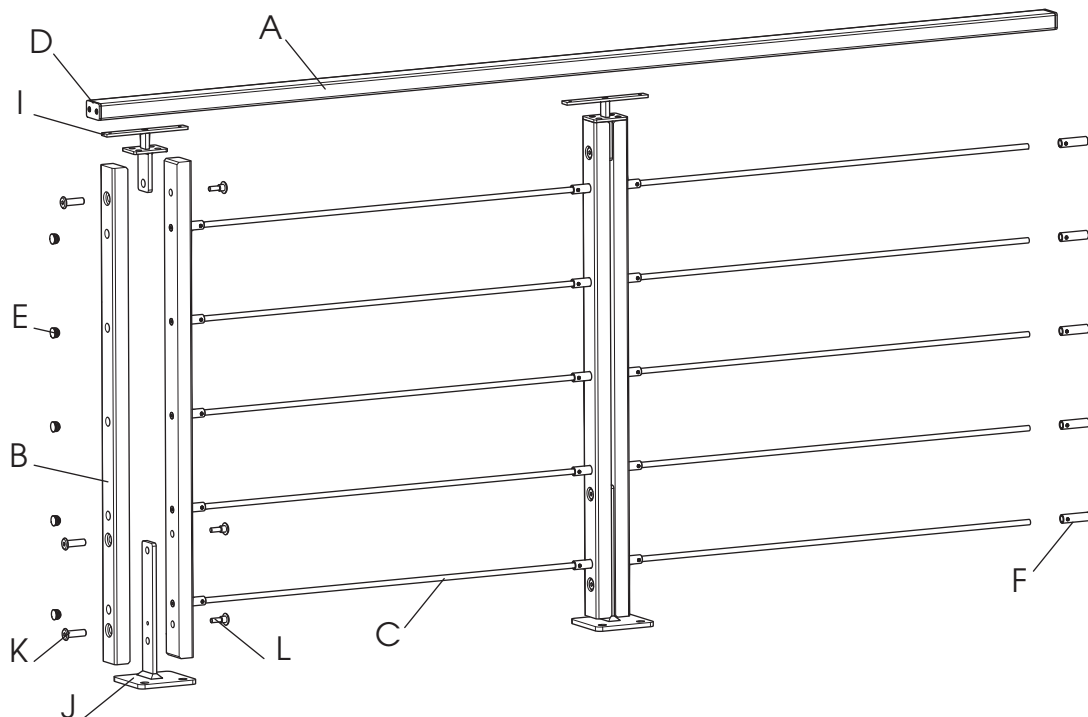

A		x1
B		x4
C		x10
D		x2
E		x10
F	 =  +  +	x20
G	Ø4x20	x8
H	Ø4,5x45	x8

I		x2
J		x2
K		x6
L		x6

Adapter son garde-corps à la norme pour une hauteur de chute supérieure à 1 m

- Adaptar la barandilla a la norma para una altura de caída superior a 1 m
- Adaptar o peitoril à norma para uma altura de queda superior a 1
- Adeguare la propria ringhiera alla norma affinché abbia un'altezza di caduta superiore a 1 m
- Pas de reling aan de norm voor een valhoogte van meer dan 1 m aan
- Adapt your handrail to the standard for a fall height over 1 m

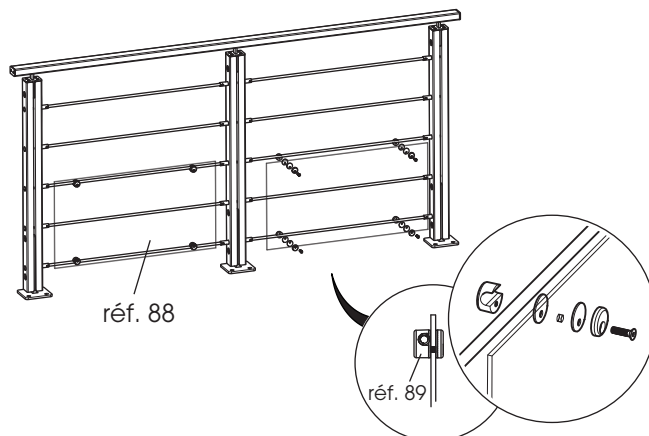

1

- Si nécessaire  
 • En caso necesario  
 • Se necessário  
 • Se necessario  
 • Indien nodig  
 • If necessary

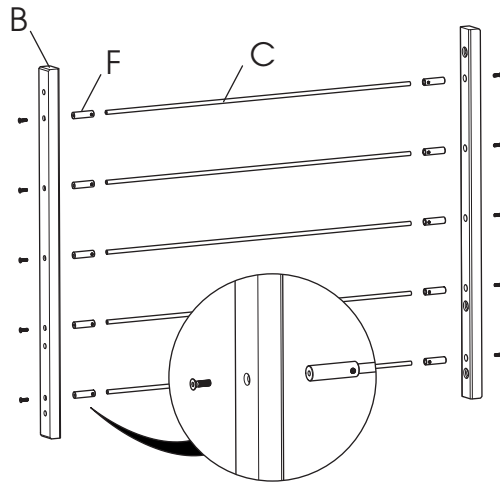
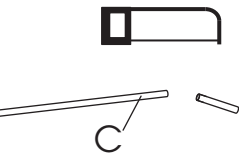

2

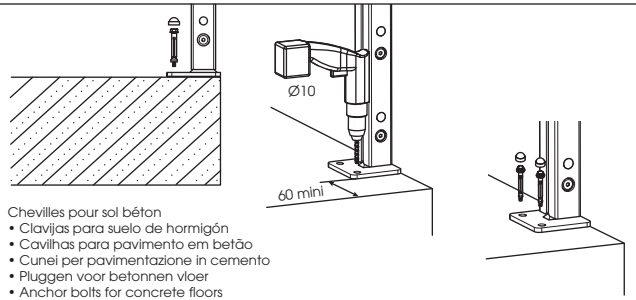
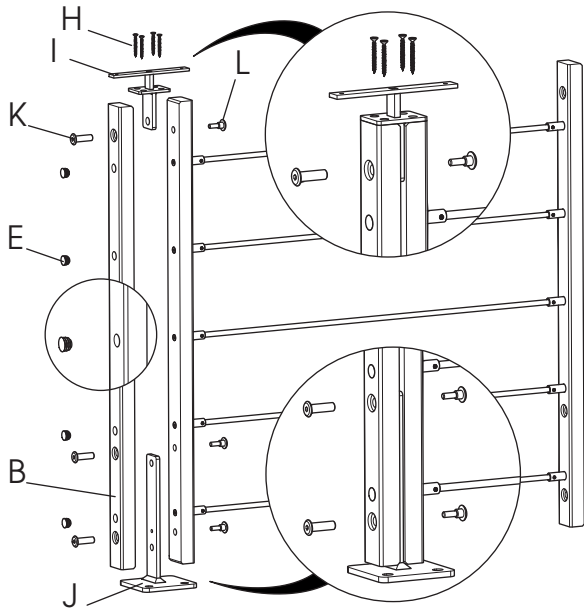

- Chevilles pour sol béton  
 • Clavijas para suelo de hormigón  
 • Caviilhas para pavimento em betão  
 • Cunei per pavimentazione in cemento  
 • Pluggen voor betonnen vloer  
 • Anchor bolts for concrete floors

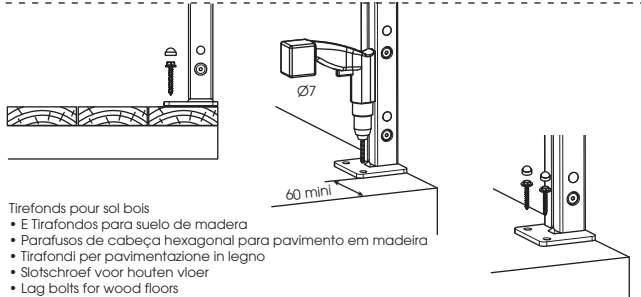

- Tirefonds pour sol bois  
 • E Tirafondos para suelo de madeira  
 • Parafusos de cabeça hexagonal para pavimento em madeira  
 • Tirafondi per pavimentazione in legno  
 • Slotschroef voor houten vloer  
 • Lag bolts for wood floors

3

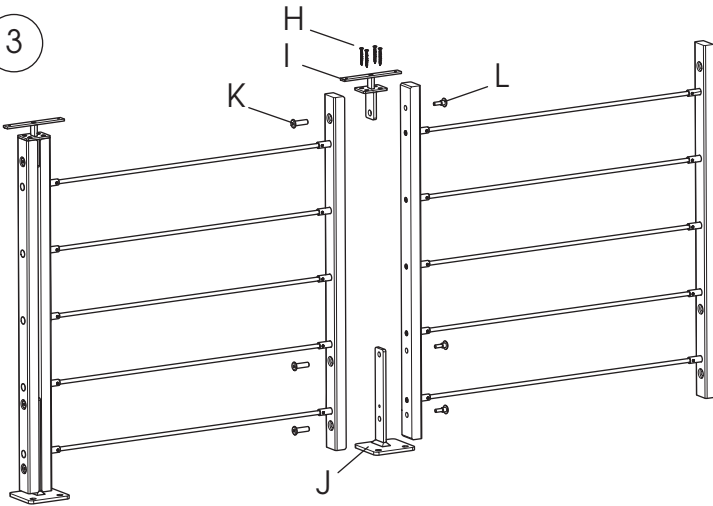

4

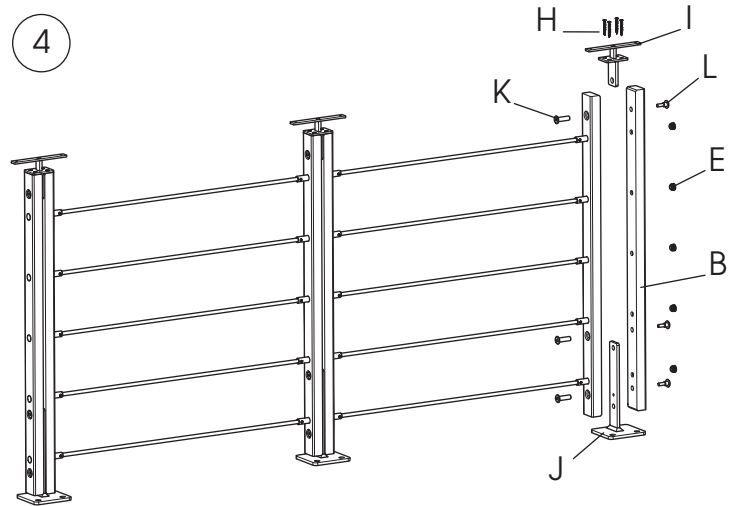

5

