

Escalier NOVAH quart tournant à droite

Réf 935

BURGER.fr

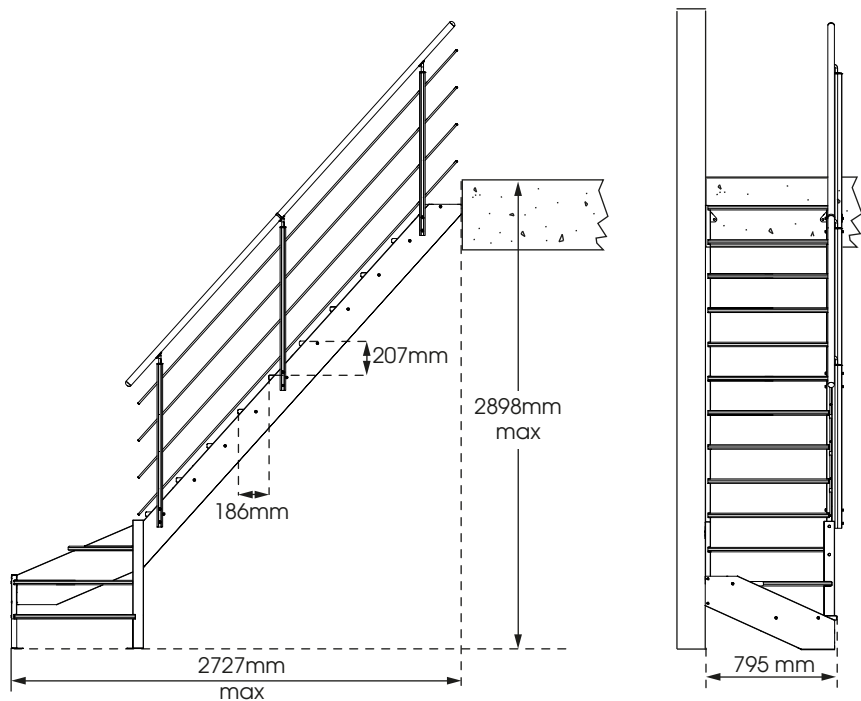
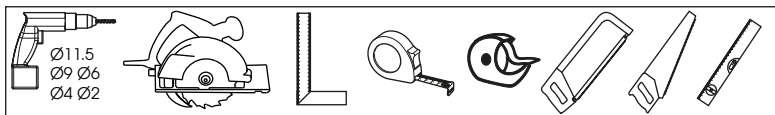
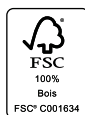

1	20831		32x190x2923 mm	x1
2	20830		32x190x2923 mm	x1
3	20826		27.2x220x735 mm	x10
4	20832		65x65x775.5 mm	x1
5	20833		32x245x897 mm	x1
6	20834		32x261x907 mm	x1
7	20835		27.2x472x735 mm	x1
8	20836		27.2x486x1019 mm	x1
9	20892		27.2x502x735 mm	x1
10	22022		34x60x986 mm	x3
11	20754		Ø40x2000 mm	x2
12	70374		Ø10x2000 mm	x8

13	72249		ref. 792	x1
14	72248			x1
15	72262		ref. 935-936	x1



A	72035		Ø4x30 mm	x8
B	72411		Ø5 x 20 mm	x6
C	72361		Ø5 x 40 mm	x15
D	72361		M6 x 20 mm	x6
E	72135		Ø6x50 mm	x28
F	72534		Ø6x70 mm	x1
G	72533		Ø6x80 mm	x2
H	72066		Ø6x100 mm	x2
I	72532		Ø7x70 mm	x2
J	72528		M8 x 100 mm	x6
K	70841		Ø35	x2
L	70339		M8	x2
M	72356		M8	x14
N	70850		Ø15	x2
O	70849		Ø12	x2
P	72301		M8	x6
Q	70352		3x73x204 mm	x1
R	70848		3x65x103 mm	x1
S	70845		3x72.5x204 mm	x1
T	70844		3x72.5x204 mm	x1
U	72361		34 x 60 x 91.5 mm	x3
V	72361		14 x 32 x 127 mm	x3
W	72361		Ø25 x 15 mm	x15
X	MGP			x1
Y	242			x1
Z	MEM1			x2
AA	MEM1		Ø40	x2
AB	70632		Ø10 x 14 mm	x8
AC	70638		Ø8 x 50 mm	x4

1

X (mm)	H (mm)
2691 ≤ X ≤ 2898	2691
2484 ≤ X ≤ 2691	2484
2277 ≤ X ≤ 2484	2277
2070 ≤ X ≤ 2277	2070
1863 ≤ X ≤ 2070	1863
1656 ≤ X ≤ 1863	1656
1449 ≤ X ≤ 1656	1449
1242 ≤ X ≤ 1449	1242
1035 ≤ X ≤ 1242	1035
828 ≤ X ≤ 1035	828

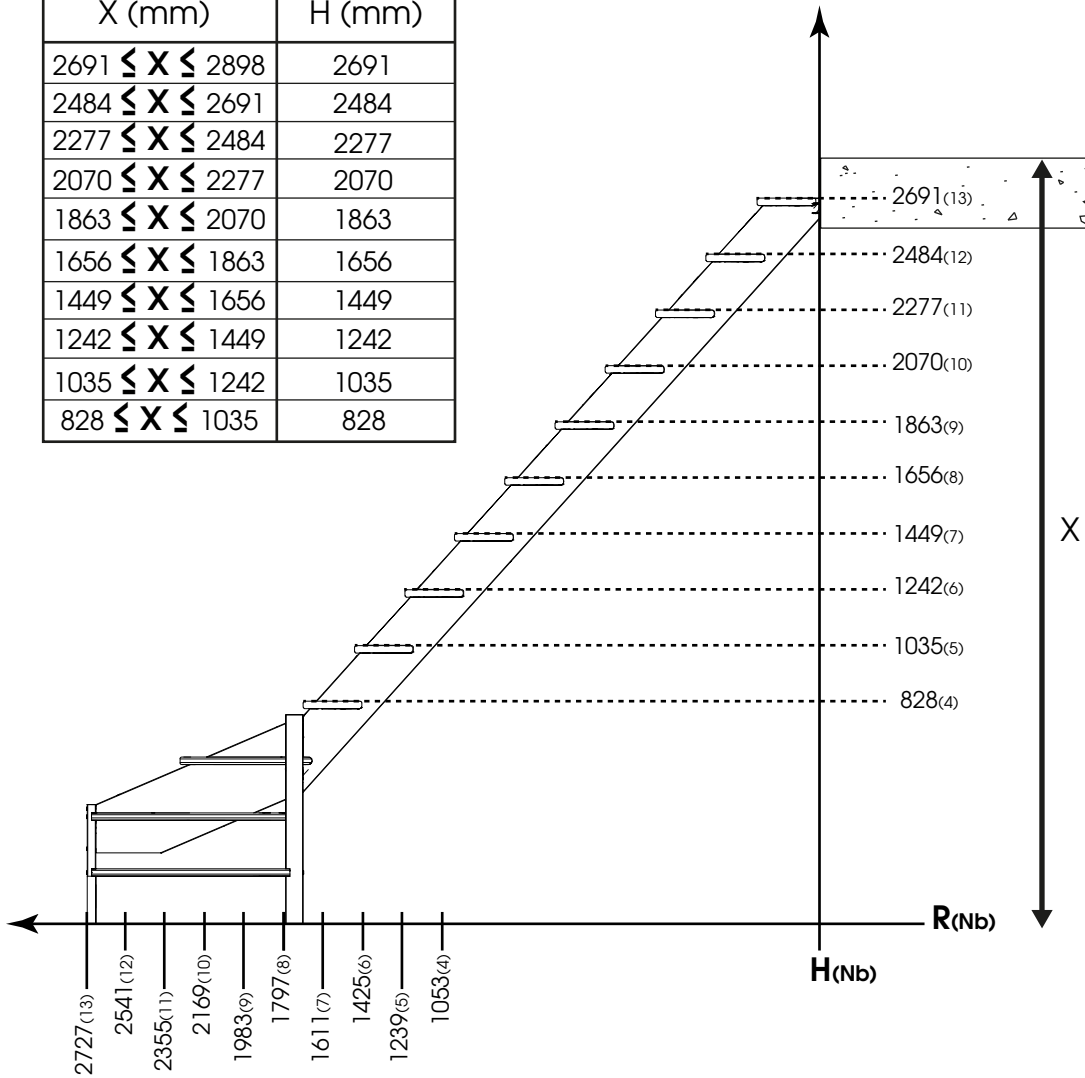

Nb: Nombre de marche
 Número de peldaños
 Número de degraus
 Numero di gradini
 Aantal treden
 Number of steps

R(mm): Reculement
 Desarrollo
 Recuo
 Lunghezza orizzontale
 Terugloop
 Going

H(mm): Hauteur escalier
 Altura escalera
 Altura da escada
 Altezza della scala
 Traphoogte
 Staircase height

X(mm): Hauteur Sol/sol
 Altura suelo/suelo
 Altura solo/solo
 Altezza pavimento/pavimento
 Hoogte vloer/vloer
 Floor-to-floor height



Prendre en compte les deux positions possibles des platines pour choisir la hauteur des points de fixation en haut de l'escalier.
 Tener en cuenta las dos posiciones posibles de las placas para elegir la altura de los puntos de fijación en lo alto de la escalera.
 Tet em conta as duas posições possíveis das placas para determinar a altura dos pontos de fixação no topo da escada.
 Per definire l'altezza dei punti di fissaggio nella parte superiore della scala, considerare le due possibili posizioni delle piastre.
 Bij het kiezen van de hoogte van de bevestigingspunten bovenaan de trap moet u ermee rekening houden dat de platen twee mogelijke posities kunnen innemen.
 Take into account the two possible positions of the plates when choosing the heights of the fastening points at the top of the staircase.

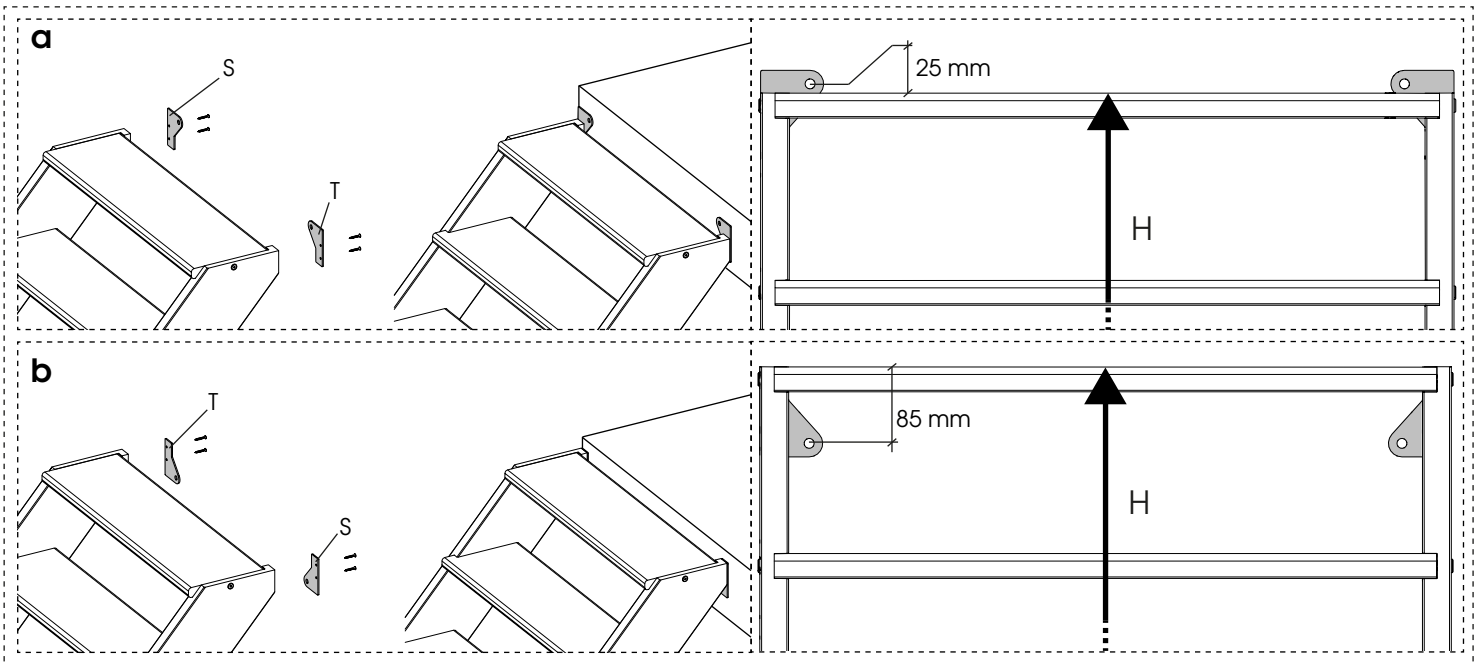

2

H (mm)	
2691	-
2484	9
2277	8
2070	7
1863	6
1656	5
1449	4
1242	3
1035	2
828	1

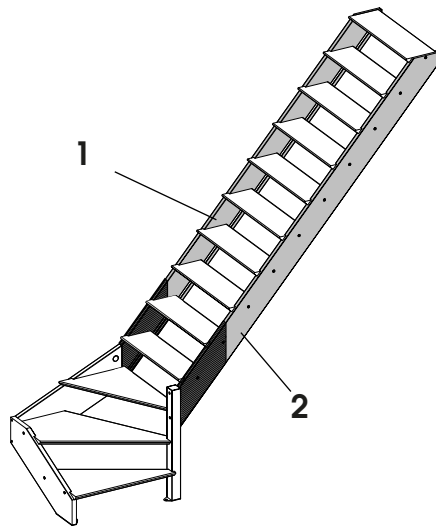

Protéger le limon avec du scotch avant de le scier
 Proteja la zanca con cinta antes de serrar o cortar
 Proteger a langorina com fitacola antes de serrar
 Proteggere il lato con l'adesivo prima di segare
 Bescherm de trapboom met tape vooraleer deze te zagen
 Protect the string board with scotchtape before sawing it

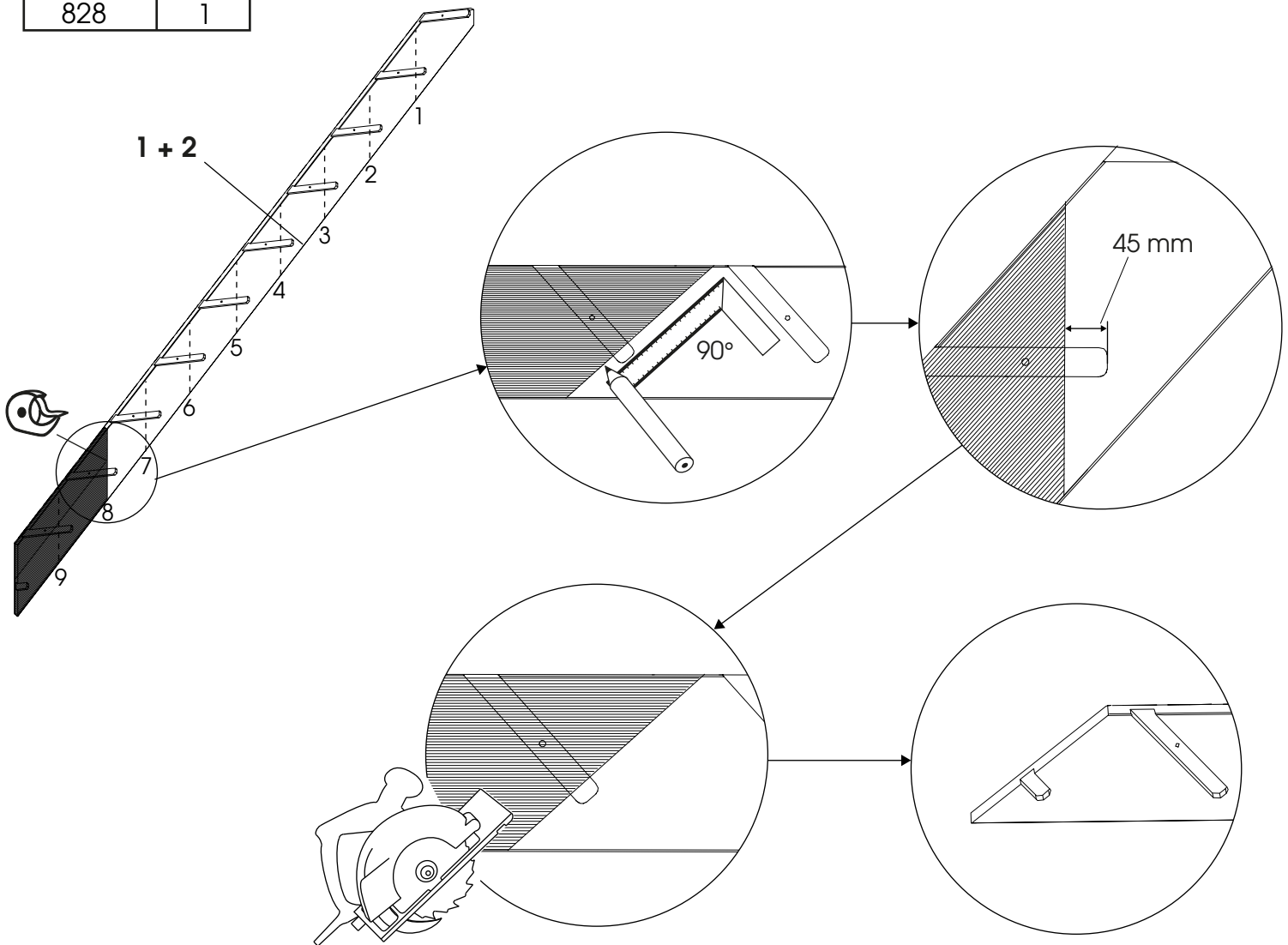

3

Appliquer un produit d'entretien (lasure, peinture) sur toutes les pièces afin de garantir la bonne tenue dans le temps de votre produit.

Aplicar un producto de mantenimiento (lasure, pintura) para asegurar un buen rendimiento en el tiempo, de su producto.

Aplicar um produto de manutenção (pintura,...) para garantir a duração do seu produto no tempo.

Applicare un prodotto di mantenimento (pittura...) per garantire una buona tenuta nel tempo del vostro prodotto.

Breng een onderhoudsproduct (beits, verf) aan zodat uw product lange tijd kan meegaan.

Apply a cleaning product (tint, paint) in order to guarantee the good quality of the product in the time.

4

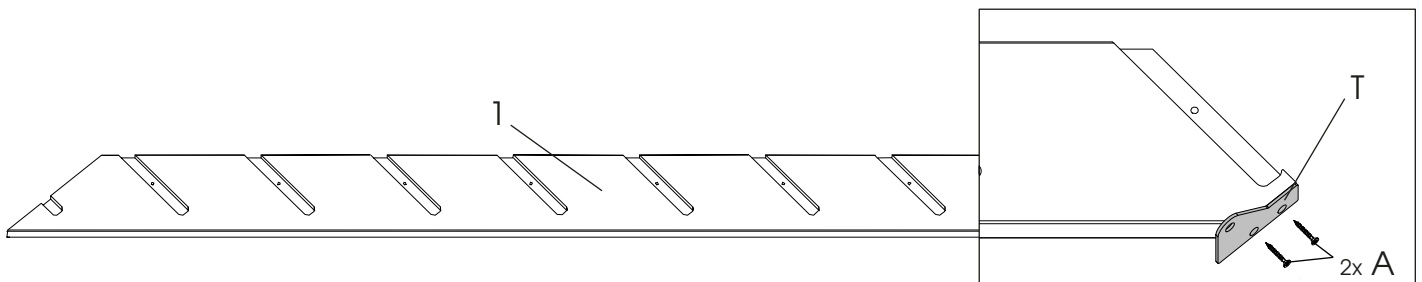
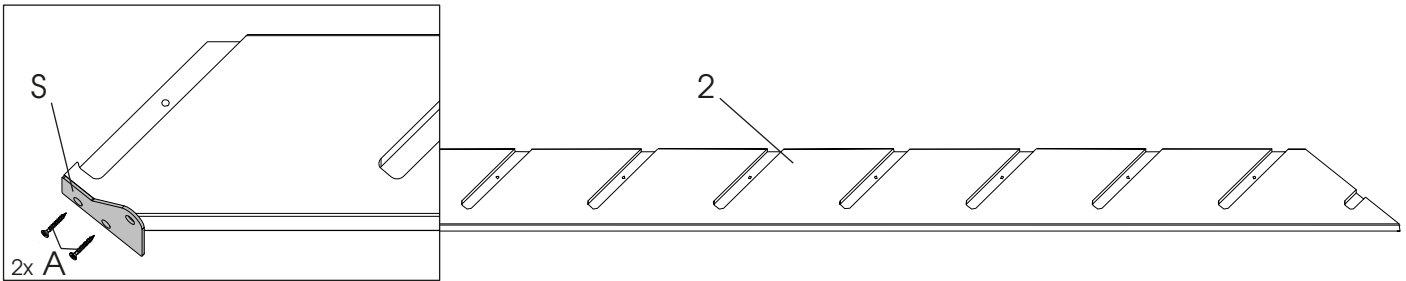
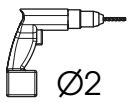
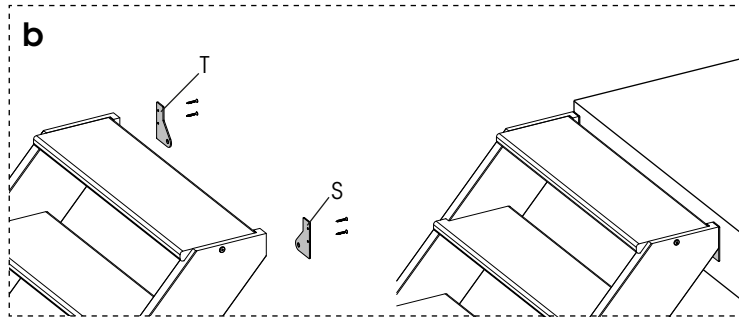
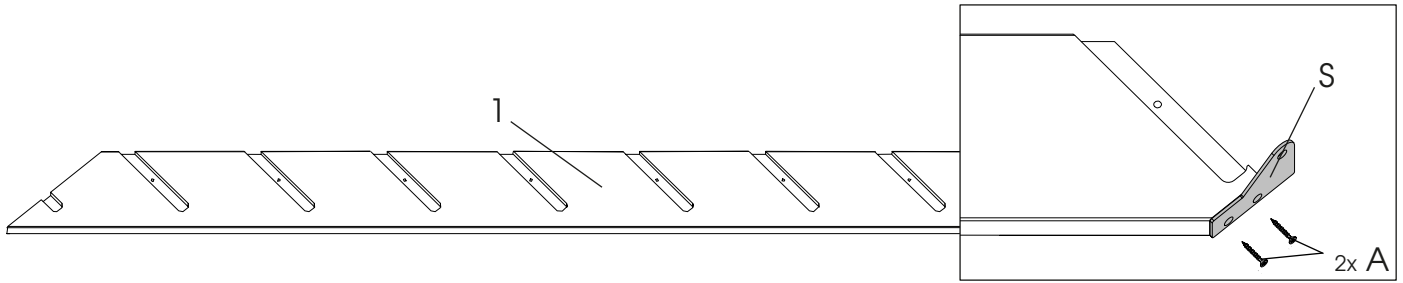
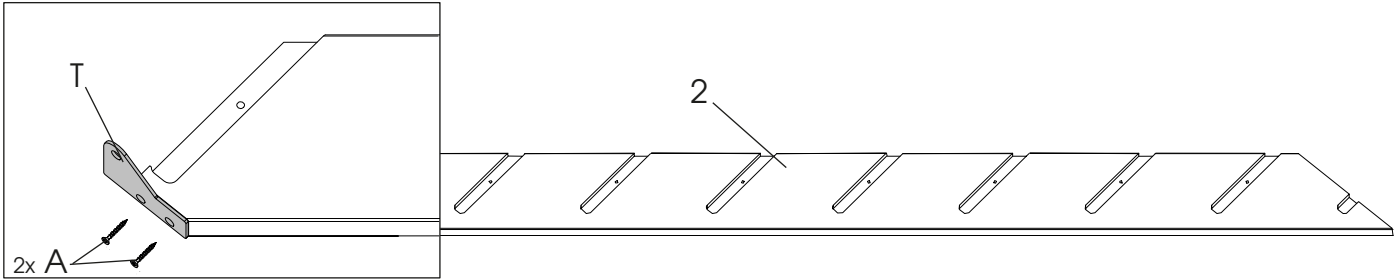
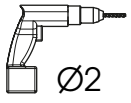
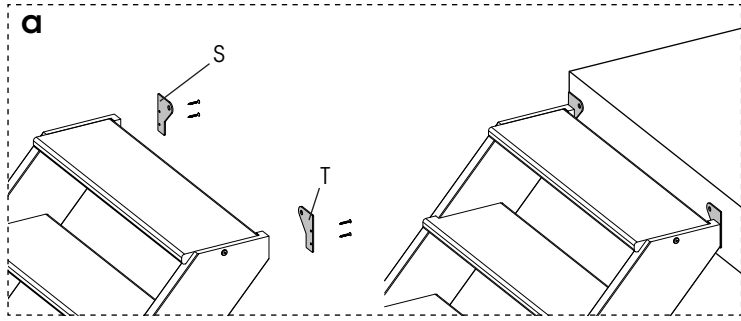

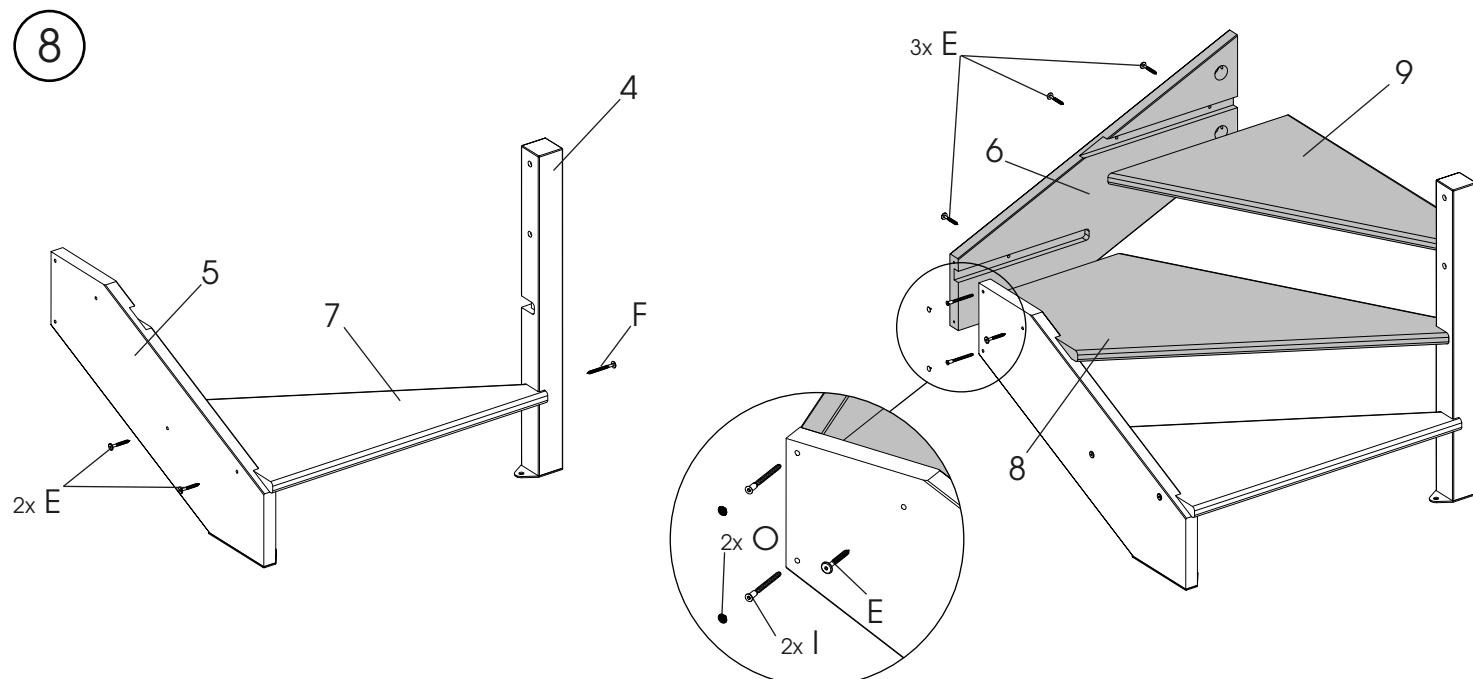
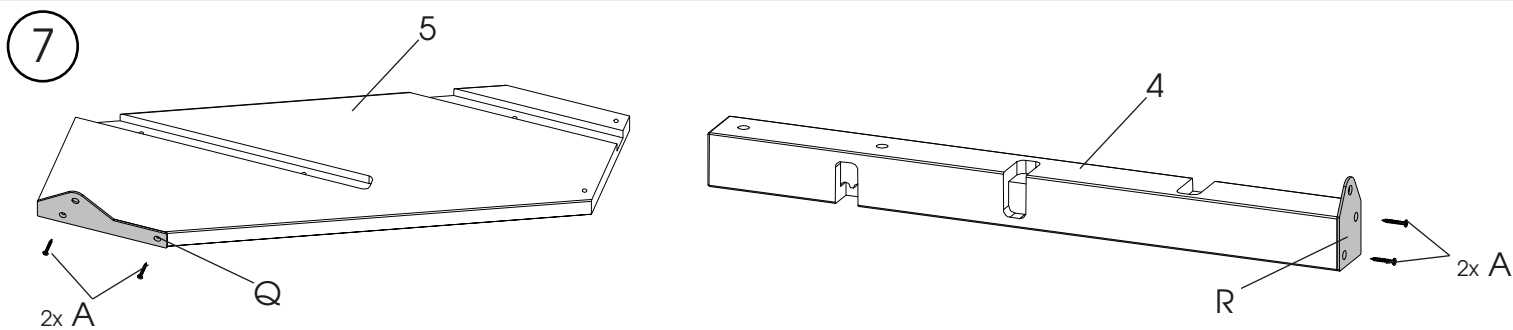
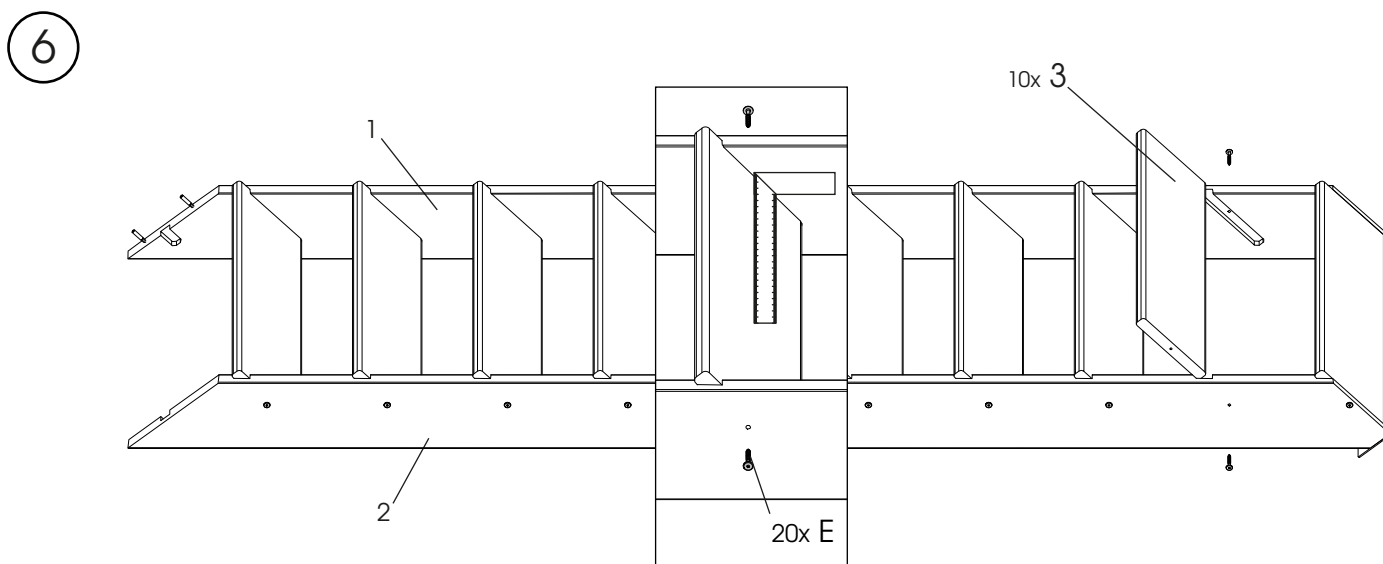
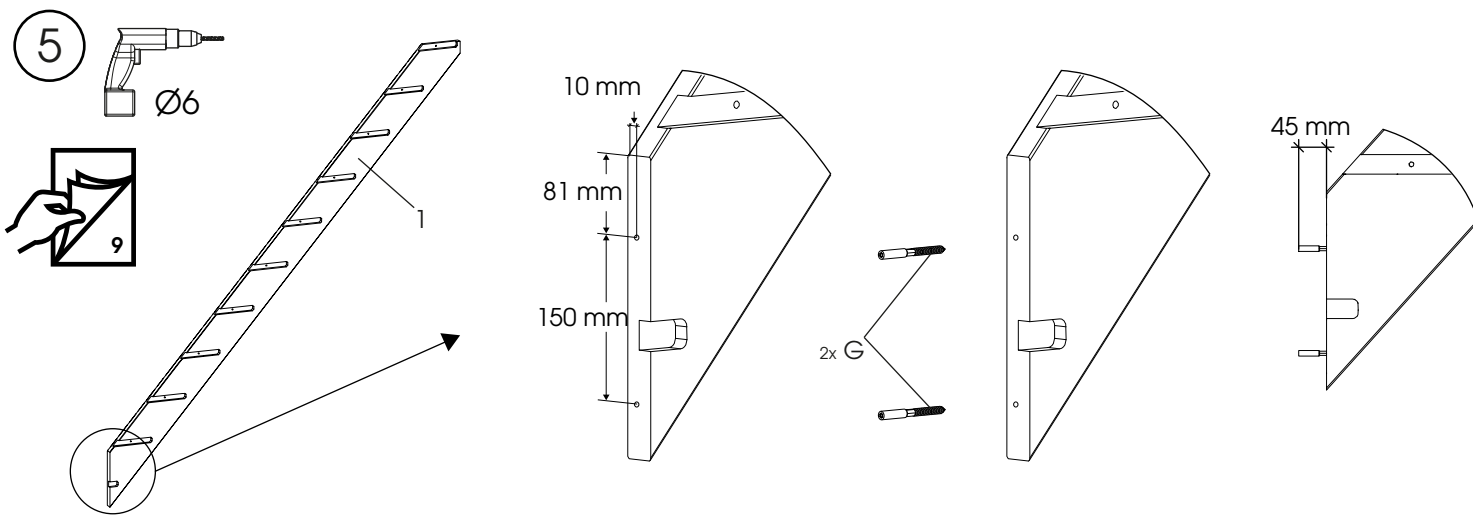

9

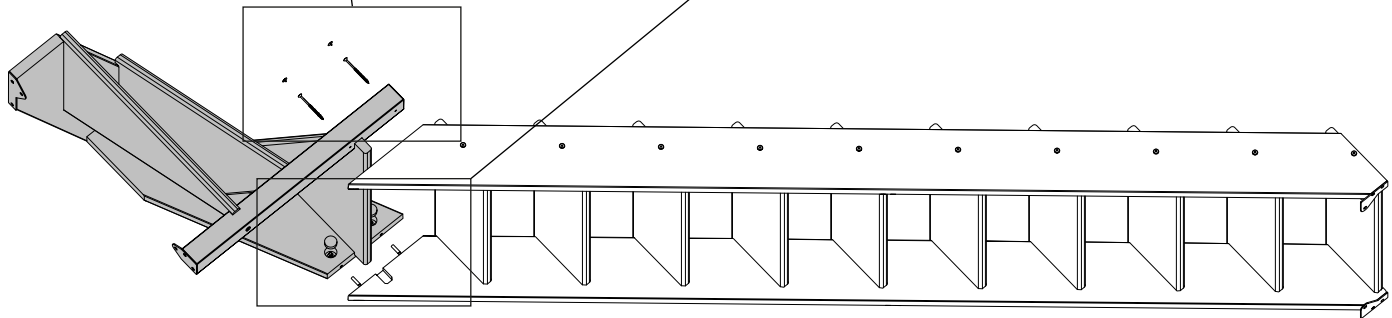
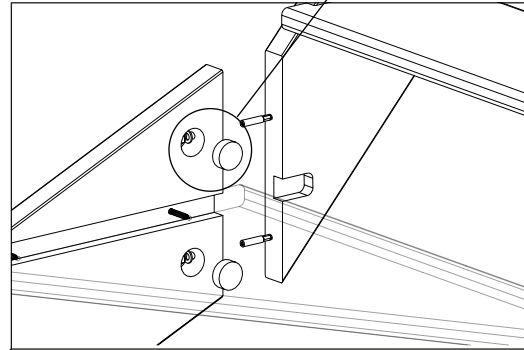
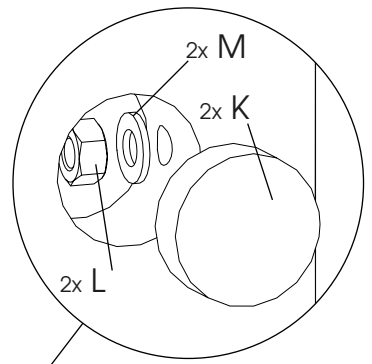
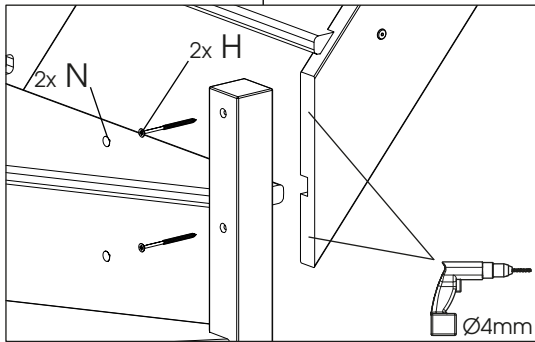
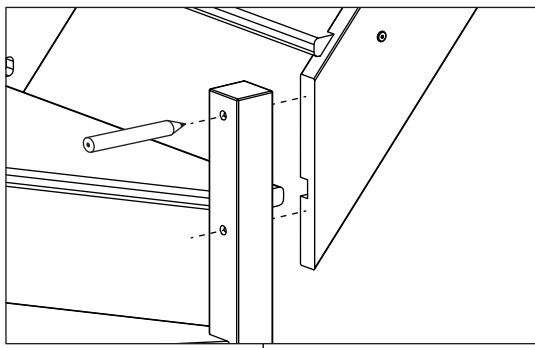

10

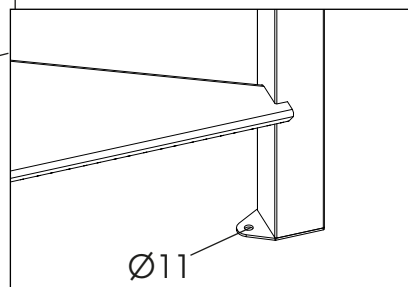
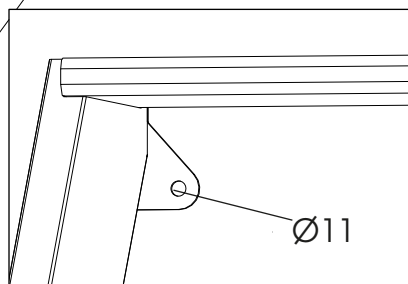
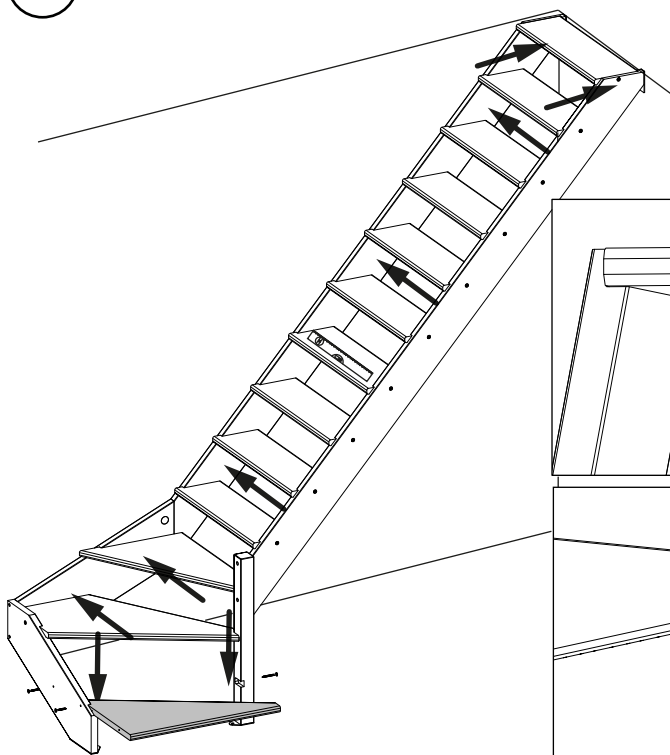

Fixer l'escalier à la dalle et au mur avec des accessoires d'ancrage adaptés.

Fijar la escalera a la losa y al muro con accesorios de anclaje adaptados.

Fixar a escada na laje e na parede com os acessórios de ancoragem adaptados.

Fissare la scala alla mattonella e al muro con gli appositi elementi di ancoraggio.

Bevestig de trap met de geschikte bevestigingsaccessoires aan de plaat en de muur.

Fasten the staircase to the floor and wall using suitable fastening accessories.

11

3x

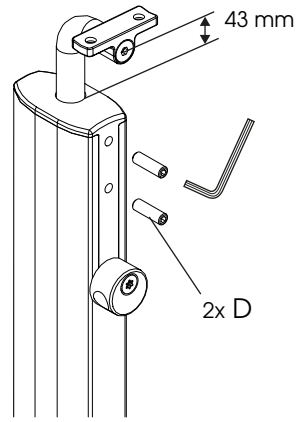
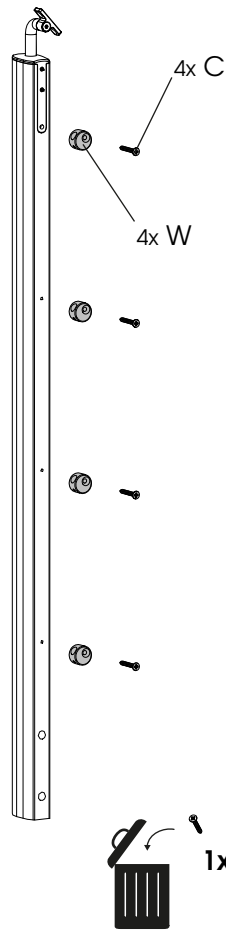
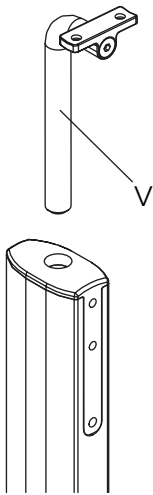
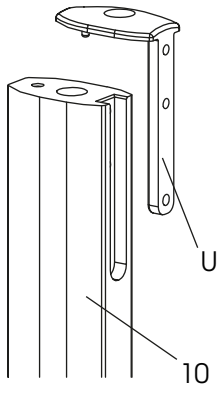

Ne pas serrer trop fort
 no apretar demaciado fuerte - Não apretar
 muito forte - non stringere troppo forte - Niet te
 krachtig vastzetten - Don't tighten too hard

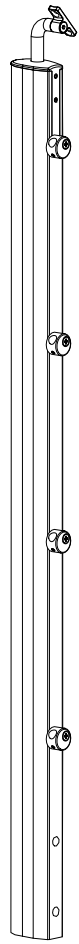
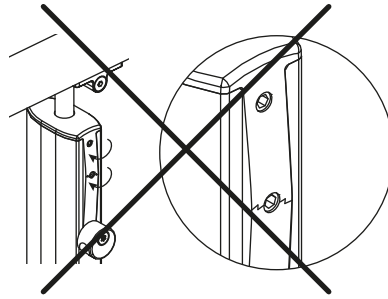

12

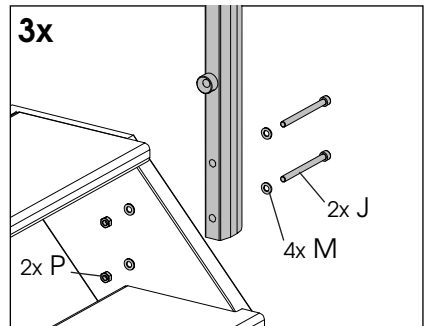
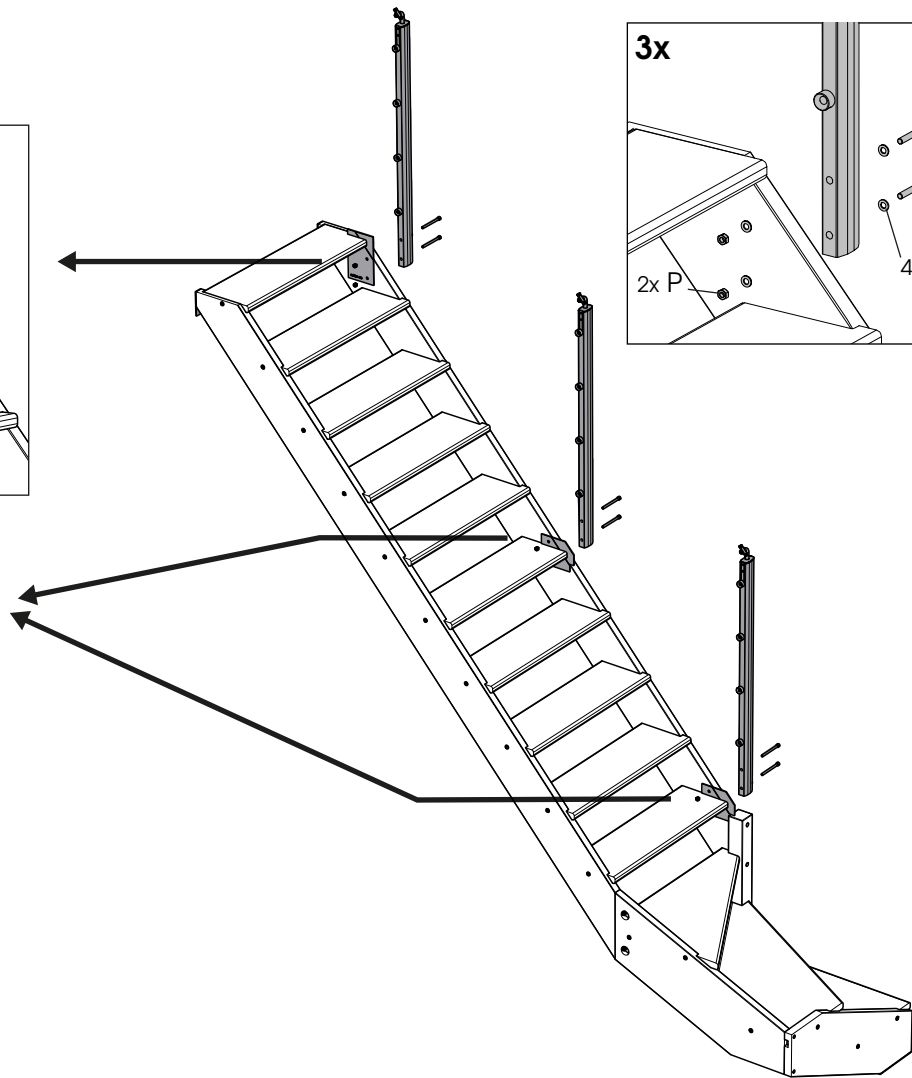
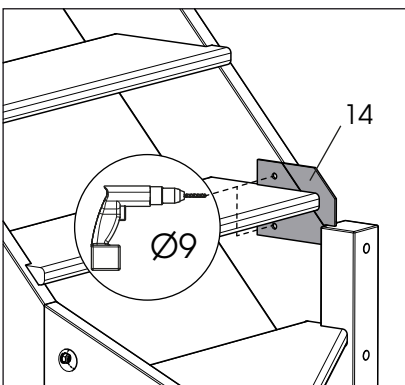
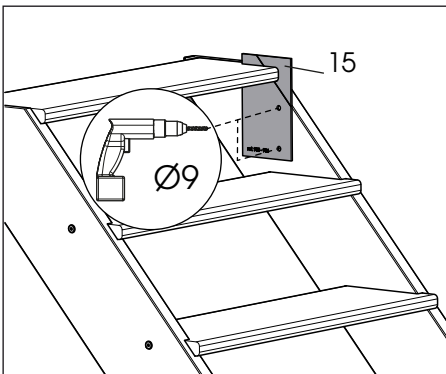

3x

13

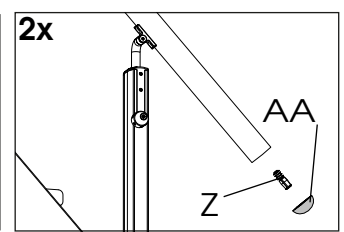
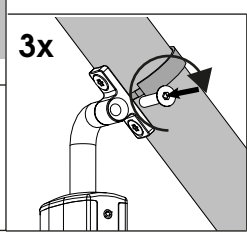
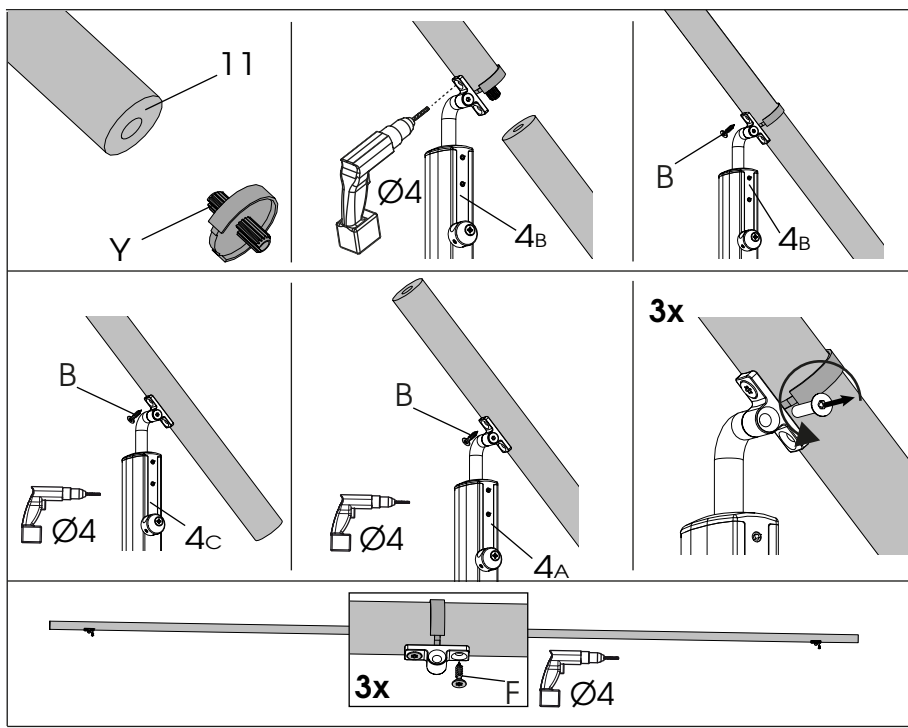
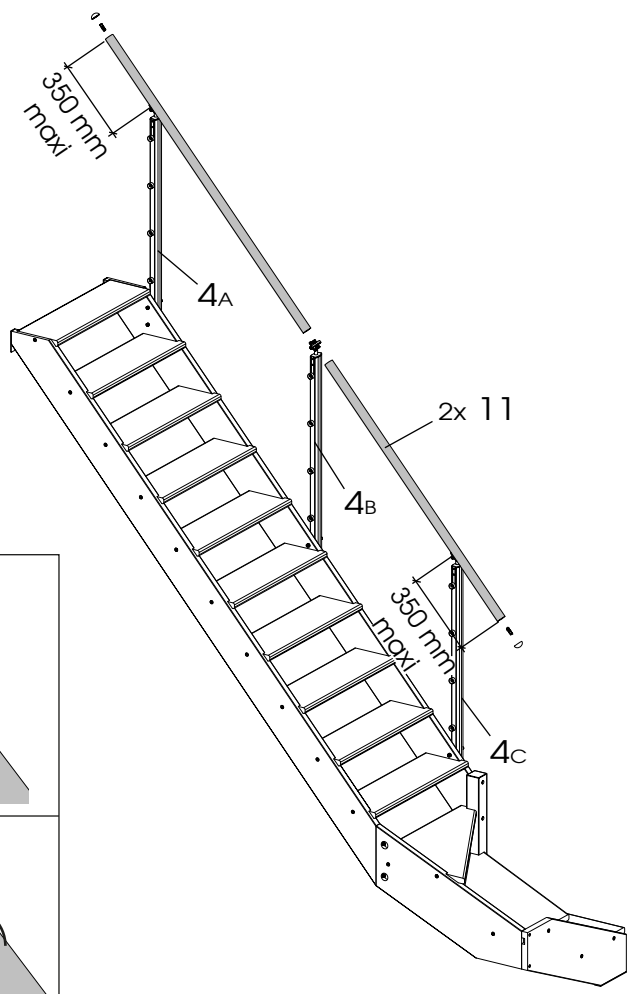
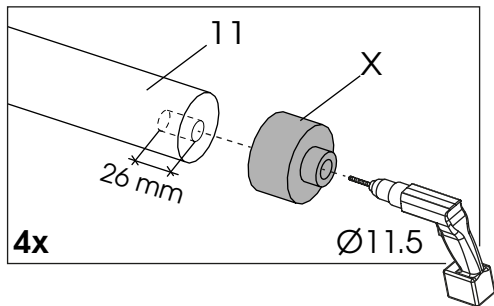
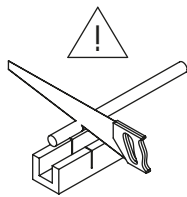

14

4x

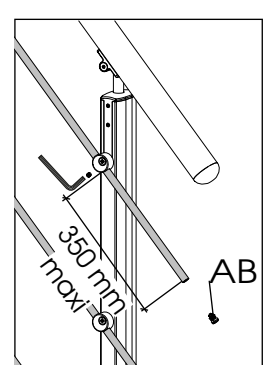
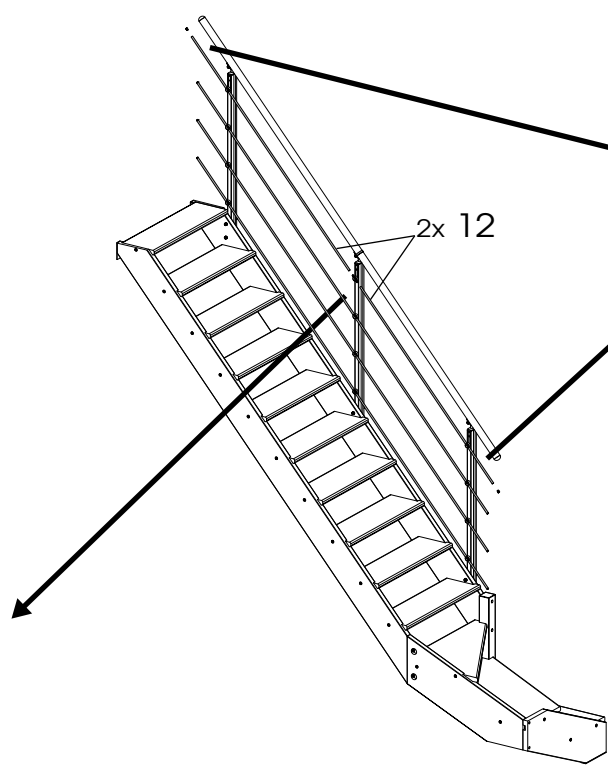
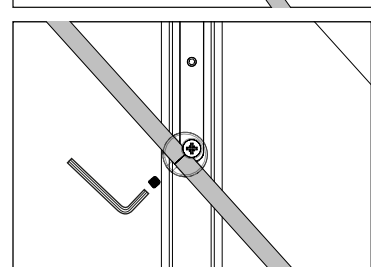
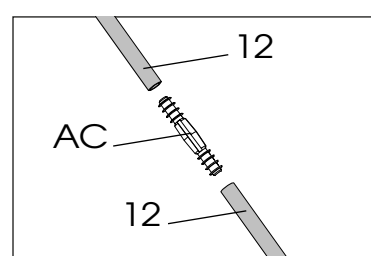
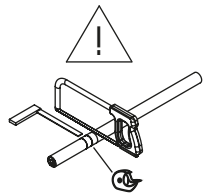

Gabarit de perçage Ø6

